

**SONY.**

3-206-637-11 (1)

# ***UHF Synthesized Diversity Tuner***

---

Operating Instructions \_\_\_\_\_

**US**

Mode d'emploi \_\_\_\_\_

**FR**

Manual de instrucciones \_\_\_\_\_

**ES**

**WRR-861A/WRR-861B**

© 2001 Sony Corporation



MLD Equipment Rental  
Dallas, TX  
800-343-2167

## Owner's Record

The model and serial numbers are located at the rear of the unit. Record the serial number in the space provided below. Refer to these numbers whenever you call upon your Sony dealer regarding this product.

**Model No.** WRR-861A/861B    **Serial No.** \_\_\_\_\_

### Notice for customers in the U.S.A.

You are cautioned that any changes or modifications not expressly approved in this manual could void your authority to operate this equipment.

*If you have any questions about this product, you may call:*

*Sony's Business Information Center (BIC)  
at 1-800-686-SONY (7669)*

*or Write to:*

*Sony Customer Information Services Center  
6900-29 Daniels Parkway, PMB 330 Fort Myers,  
Florida 33912*

### Declaration of Conformity

Trade Name:            SONY  
Model No.:            WRR-861B  
Responsible Party:   Sony Electronics Inc.  
Address:                680 Kinderkamack Road,  
                              Oradell, NJ 07649 U.S.A.  
Telephone No.:        201-930-6972

This device complies with Part 15 of the FCC Rules. Operation is subject to the following two conditions:  
(1) This device may not cause harmful interference, and  
(2) this device must accept any interference received, including interference that may cause undesired operation.

## **Notice for customers in Canada:**

Use of Sony wireless devices is regulated by the Industry Canada as described in their Radio Standard Specification RSS-123.

A licence is normally required. The local district office of Industry Canada should therefore be contacted. When the operation of the device is within the broadcast band, the licence is issued on no-interference, no-protection basis with respect to broadcast signals.

Operation of this device is subject to the following two conditions: (1) this device may not cause interference, and (2) this device must accept any interference, including interference that may cause undesired operation of the device.

## **Avis pour les clients au Canada:**

L'usage des appareils sans-fil Sony est réglé par l'Industrie Canada comme décrit dans leur Cahier des Normes Radioélectriques CNR-123.

Une licence est normalement requise. Le bureau de l'Industrie Canada doit être contacté. Lorsque l'opération de l'appareil est dans les limites de la bande de radiodiffusion, la licence est émanée sur la base de non-interférence, non-protection avec les signaux de radiodiffusion.

L'utilisation de cet appareil est soumise aux deux conditions suivantes : (1) cet appareil ne peut causer d'interférences, et (2) cet appareil doit accepter toutes les interférences, y compris les interférences capables de provoquer un fonctionnement indésirable de l'appareil.

<b>Precautions</b> .....	<b>1</b>
<b>Overview</b> .....	<b>2</b>
Features .....	2
<b>Parts Identification</b> .....	<b>3</b>
<b>Power Supply</b> .....	<b>6</b>
<b>Settings</b> .....	<b>8</b>
Connections .....	8
Wireless Channel Selection .....	8
Setting the Squelch Level .....	11
Resetting the Accumulated Time Indication .....	12
Selecting the Backlight Mode .....	13
Attaching to a Camcorder .....	13
<b>Error Messages</b> .....	<b>14</b>
<b>Troubleshooting</b> .....	<b>15</b>
<b>Specifications</b> .....	<b>17</b>

- The unit is designed for use in ambient temperature range of 0°C to 50°C (32°F to 122°F).
- Do not place the unit on or near heat sources, such as lighting equipment, power amplifiers, or in a place subject to direct sunlight or excessive moisture. In such places, the external finish or internal parts of the unit may be damaged.
- If the unit is used in a very humid or dusty place or in a place subject to an active or corrosive gas, clean its surface as well as the connectors with a dry, soft cloth soon after use.  
Lengthy use of the unit in such places or not cleaning it after its use in such places may shorten its life.
- When cleaning the unit, never use organic solvents such as thinners or benzine, which will damage the finish of the unit.
- The unit has been factory adjusted precisely. Do not tamper with its internal parts or attempt to repair it.

# Overview

The WRR-861A/861B is a highly reliable diversity tuner for the Sony UHF wireless microphone system to be used for broadcast or movie production purposes. This tuner is suitable for Electronic News Gathering (ENG) and Electronic Field Production (EFP).

The microphone/transmitter and tuners of the wireless microphone system are classified by frequency band. In building a UHF wireless microphone system, be sure to combine a microphone/transmitter and a tuner having the same wireless channel (frequency).

## Features

### Space Diversity Reception

A space diversity system is employed to eliminate signal dropout and provide stable reception. An SMC9-4S (Sony 4 pin) audio output connector is provided on the top panel.

### Two way powering

Approximate eight hours of continuous operation is provided by using four LR6 (size AA) alkaline batteries. The WRR-861A/861B can also be operated on the external power from Sony camcorders via the supplied DC cable.

### Battery alarm for a transmitter

The WRR-861A/861B has capability of receiving "Battery status information" from a transmitter to make advance warning of battery depletion. The information is sent in about one hour advance to battery exhaust so that you can safely replace the batteries of the transmitter.

### Selectable RF squelch

The RF squelch can be easily turned ON or OFF with the panel switch. The RF squelch level is selectable from 5 dB $\mu$ , 10 dB $\mu$  and 15 dB $\mu$ .

### Preprogrammed wireless channel plans for simultaneous multi channel operation

The WRR-861A/861B has many preprogrammed channel groups, meaning combination of wireless channels to permit simultaneous operation of multiple channels without intermodulation.

*See "Wireless Microphone System Frequency List" supplied with this manual.*

### Wide Operating Frequency ranges

WRR-861A (available in Australia):

792 to 806 MHz, TV channels 66 to 67

WRR-861B (available in the U.S.A.)

758 to 782 MHz, TV channels 62 to 65 (6264 model)

782 to 806 MHz, TV channels 66 to 69 (6668 model)

## Parts Identification

### Extensive information by the LEDs and LCD display

The LEDs indicate RF input level (green/ red indication), diversity reception status, and transmitter battery alarm. The LCD display indicates the operating channel/frequency, AF output level, RF input level, battery status of the tuner, and the accumulated operating time.

### Compact, lightweight and easy to mount on Sony camcorders

The WRR-861A/861B is compact and lightweight, housing in the rugged, die-cast magnesium case. It is easily mounted on Sony camcorders.

### Output monitoring

The monitor volume is adjustable with a knob.

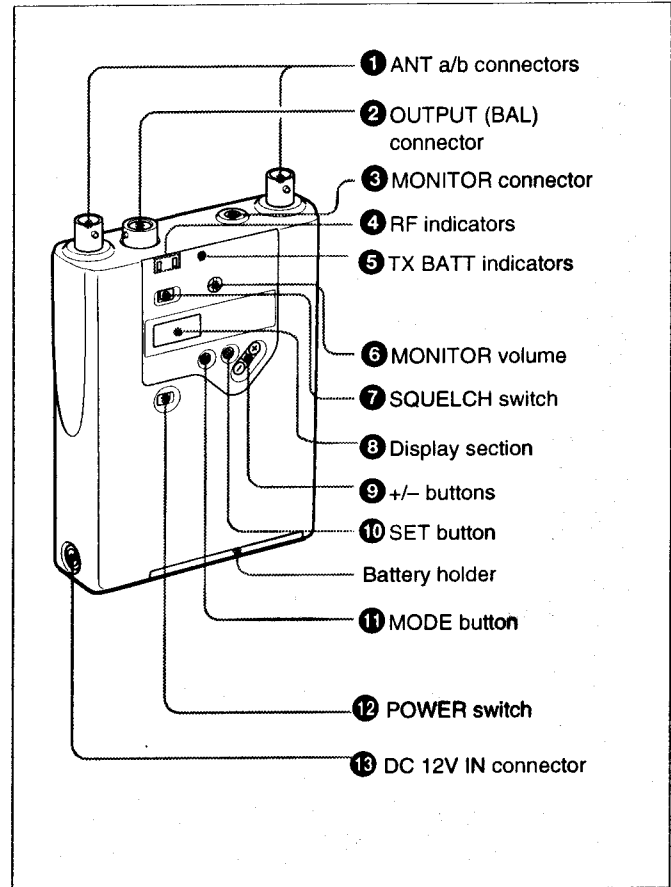

## Parts Identification

### ① ANT (antenna) a/b connectors

Connect the antennas supplied to both ANT a/b connectors.

#### Note

Be sure to connect two antennas to these connectors to make the diversity reception properly.

### ② OUTPUT (BAL) connector

The OUTPUT connector supplies audio signal output from the tuner.

Connect this connector to the microphone input connector of a camcorder, mixer, or tape recorder by using the supplied cable.

### ③ MONITOR connector

To monitor the tuner output, connect the headphones, equipped with a 3.5 mm ( $\frac{5}{32}$  inch) dia stereo mini plug. Use either of stereo or monaural headphones. Adjust the monitor level with the MONITOR volume.

### ④ RF (radio frequency) indicators

Indicate the strength of the RF input signal and the receiving antenna for diversity reception of the tuner. The indication color shows the strength of the RF input signal. The indicated signal level changes corresponding to the squelch level setting.

When the squelch level is set to 5 dB $\mu$ ;

On in green: RF input is more than 15 dB $\mu$ .

On in red: RF input is between 5 dB $\mu$  and 15 dB $\mu$ .

Off: RF input is less than 5 dB $\mu$ .

When the squelch level is set to 10 dB $\mu$ ;

On in green: RF input is more than 20 dB $\mu$ .

On in red: RF input is between 10 dB $\mu$  and 20 dB $\mu$ .

Off: RF input is less than 10 dB $\mu$ .

When the squelch level is set to 15 dB $\mu$ ;

On in green: RF input is more than 25 dB $\mu$ .

On in red: RF input is between 15 dB $\mu$  and 25 dB $\mu$ .

Off: RF input is less than 15 dB $\mu$ .

### ⑤ TX BATT (transmitter battery) indicator

Shows the battery condition of the wireless microphone transmitter. The indicator starts flashing about one hour before the transmitter batteries go flat.

### ⑥ MONITOR volume

Turn to adjust the monitoring level through headphones.

### ⑦ SQUELCH switch

In ordinary use, set the switch to ON, and the noise and signal interference will be eliminated when the tuner is in signal reception stand-by mode. Set to OFF to search outside noise or a radio wave which may disrupt the transmission.

#### Note

If you turn off the SQUELCH switch when the tuner is in stand-by condition for signal receiving or when the RF input level is low, noise may be heard or the connected device or speakers may be damaged. Be sure to operate this switch only after minimizing the input of the connected device.

See "Setting the Squelch Level" on page 11.

## Ⓑ Display section

Shows the status of the tuner.

For details of each indication, see Ⓐ to Ⓓ.

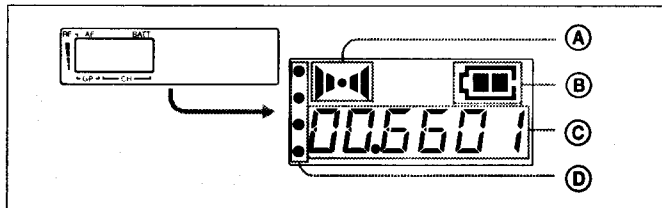

### Ⓐ AF (audio frequency) indication

Lights when the output audio signal is over the reference level.

### Ⓑ BATT (battery) indication

Displays the status of the batteries of this tuner.

See "Battery indication" on page 6.

### Ⓒ GP/CH (group/channel) indication

Shows the receiving channel group and channel number.

Each time you press the MODE button the group/channel indication changes to the frequency, squelch level, accumulated operating time and backlight mode indications.

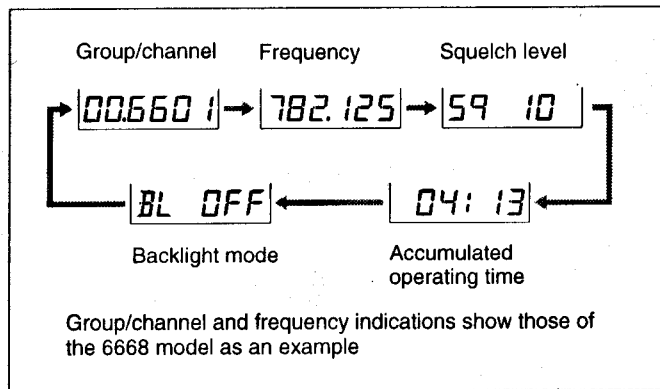

For each item setting, see page 8 to 13.

### Ⓓ RF (radio frequency) indications

The number of dots shows the RF input level as below.

Four dots on:	more than 35 dB $\mu$
Three dots on:	between 25 dB $\mu$ and 35 dB $\mu$
Two dots on:	between 15 dB $\mu$ and 25 dB $\mu$
One dot on:	between 5 dB $\mu$ and 15 dB $\mu$
No dot:	less than 5 dB $\mu$

### Ⓘ + (+ selection) / - (- selection/reset) buttons

When setting the transmission channel, frequency, squelch level and backlight mode, press these buttons to change its contents. The "-" button resets the accumulated time indication to "00:00".

## Parts Identification

### 10 SET button

Press to set and fix the item on the display.

*For details, see "Settings" on page 8.*

### 11 MODE button

Press to select the item shown on the display.

*For details, see "Settings" on page 8.*

### 12 POWER switch

Turns the power of the tuner ON or OFF.

### 13 DC 12V IN connector

For external power operation, connect to an external power supply (DC 10 V to 17 V) of a camcorder using the supplied power cable.

When the external power is supplied, the tuner functions regardless of the built-in batteries.

*For connecting the antennas, output cables and DC power cable and attaching the unit to a camcorder, see "Connections" on page 8 and "Attaching to a Camcorder" on page 13.*

## Power Supply

### Installing the batteries

The tuner can operate on four LR6 (size AA) alkaline batteries continuously for about 8 hours at 25°C (77 °F).

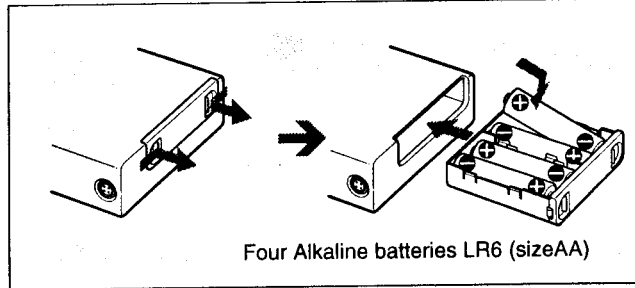

- 1 Slide the battery-holder catches inward to take out the battery holder.
- 2 Match the polarities and insert the batteries.
- 3 Set the battery holder in the original position. Confirm that both catches on the holder are locked.





### Battery indication

When you turn the power on, the battery status of this unit appears in the BATT indication on the display section.

When the BATT indication starts to flash as indicated in the column 4 on the table on the next page, immediately replace all four batteries with new ones. Before installing the new batteries, be sure to check the recommended period of usage indicated on the batteries.

**Note**

The indication may be incorrect if the batteries are not new when installed. If you plan to use the tuner for a long period, it is best to replace the batteries with new ones.

	1	2	3	4
<b>BATT indication</b>	Lights 	Lights 	Lights 	Flashes 
<b>BATT condition</b>	Good	Less than 50% charge	Less than 20% charge	Almost exhausted

**Notes on batteries**

- Use new alkaline batteries.
- Do not use different types of batteries together.
- Always replace the four batteries together.
- Be careful to install the batteries with the correct polarity.
- The batteries are not rechargeable.
- When not using the tuner for a long period, remove the batteries to avoid leakage. If the batteries do leak, clean all leakage from the battery holder case and the unit. Leakage left in the holder case and the unit may cause poor battery contact. If there seems to be poor battery contact, consult your Sony dealer.

**External power operation**

To operate on an external power supply (DC 10 V to 17 V), connect the DC 12V IN connector to the DC OUT connector of a camcorder using the power cable supplied. When the external power is supplied, the tuner functions regardless of the built-in batteries.

# Settings

To set the tuner in Setting Mode, press the SET button. The indication on the display starts to flash waiting for you to press the +/- buttons to change the contents on the display. The Setting Mode is automatically cancelled if no buttons are pressed for 30 seconds while the indication flashes.

## Connections

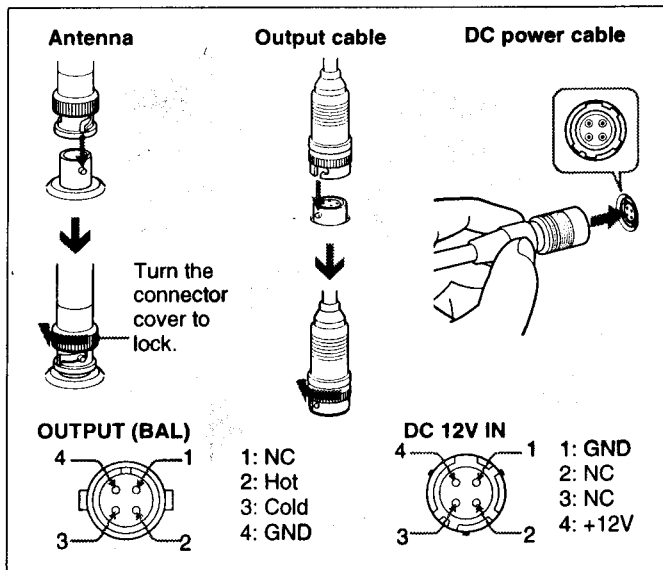

When connecting antennas and cables, match the guides of the male and female connectors.

The DC power cable can be released by pulling out the connector cover.

## Wireless Channel Selection

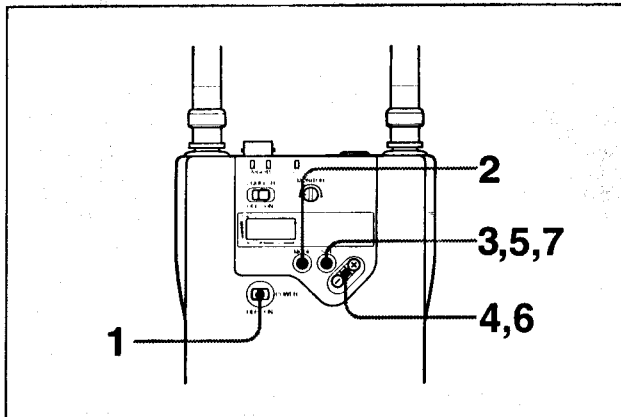

### Note

Noise may occur when the power is turned on or off. Be sure to turn down the input level of the connected equipment before operating the POWER switch.

**1** Set the POWER switch to ON.

The display shows the same status as before the tuner was last turned off.

If the group name and channel number is shown on the display, skip step **2** and proceed with step **3**.

**2** Press the MODE button until the group and channel number appear on the display.

**3** Press the SET button.

The group indication starts flashing.

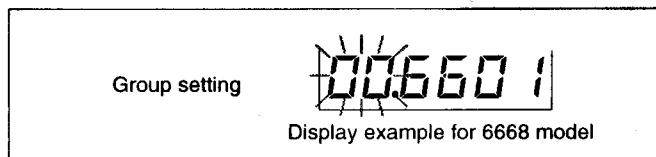

**4** Press the + or – button to select the desired group. Pressing the + button cyclically changes the group in the following order. Pressing the – button changes it in the reverse order.

**Note**

After 30 seconds of non-operation period, the indication stops flashing and the tuner exits the setting mode. The item displayed at this time is stored in memory. Note that this applies to all other item selection.

If you hold the button down, the group will continuously change.

Model available in USA

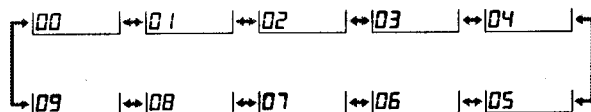

Model available in Australia

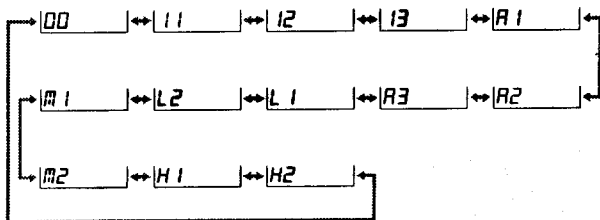

# Settings

- When the desired group appears, press the SET button again.  
The group selected is fixed.  
The tuner now enters the wireless channel setting mode, and both of the TV channel number and 2-digit number flash on the display.

Channel setting



Display example for 6668 model

- Press the + or - button to select the desired wireless channel.  
The wireless channels change in the order listed on the table of the group on the "Wireless Microphone System Frequency List" supplied with this manual.

When the group 00 is selected for 6668 model

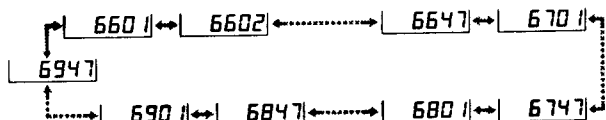

- When the desired wireless channel appears, press the SET button.  
The display stops flashing and the selected group and wireless channel are now stored in memory.

## To select the channel by frequency indication

- Turn on the unit.
- Press the MODE button until the frequency indication appears.
- Press the SET button.  
The frequency indication starts flashing.

Display example for 6668 model

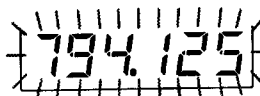

- Press the + or - button to select the desired channel frequency.
- When the desired frequency appears, press the SET button.  
The display stops flashing and the selected wireless channel is now stored in memory.

## If noise is heard

Depending on the environment where the system is installed, outside noise or radio wave may disrupt the transmission of certain channels.

To select a channel under this circumstance, turn off the wireless microphone or transmitter. Then select a channel at which the RF indicator is off. (A channel free from noise or radio wave interference is selected.) Set the same channel on the microphone or transmitter.

#### Notes

- Do not remove the batteries during group and wireless channel selection. If they are inadvertently removed, re-insert them immediately and repeat the steps on pages 9 to 10 from the beginning.
- Make sure that the same channel is selected on the tuner, wireless microphone, and transmitter within the same system.
- If there is a TV broadcasting station near by, do not use the station's channel.
- The unit may not operate correctly if it is turned on again immediately after turning off the power while in setting mode. Pause for a few seconds or more before turning on the power again.
- When operating two or more UHF wireless microphone systems using channels in different groups, ensure that the systems are at least 100 m (330 feet) apart from each other. (The same applies also when using channels in a group if the different UHF wireless microphone systems are installed where they are within sight of each other.)

## Setting the Squelch Level

You can eliminate the noise and signal interference which may occur in reception stand-by mode. Select a squelch level from 5 dB $\mu$ , 10 dB $\mu$  or 15 dB $\mu$ . The factory preset level is 10 dB $\mu$ . To obtain a wide service area, set this to 5 dB $\mu$ . When using the tuner in a multi-channel system or when you want to receive noise free audio input all the time, set it to 15 dB $\mu$ .

- 1 Press the MODE button until the squelch level appears.
- 2 Press the SET button.  
The squelch level indication starts flashing.

Squelch level



- 3 Press the + or - button to select the desired level.
- 4 When the desired level appears, press the SET button.  
The display stops flashing and the selected level is now stored in memory.

# Settings

## Squelch functions

When the SQUELCH switch is set to ON, the following functions work in combination.

### (1) Squelching by RF input level

As sufficient S/N for the audio output may not be obtained if no RF signal is received or the RF input level is low, the audio output is squelched when the RF input level falls below the squelch level selected.

### (2) Tone squelch

The audio output is obtained only when the unit receives an RF signal which includes a specified tone signal. The audio output is squelched to eliminate noise which may be heard when the transmitter is turned on/off or the unit receives an interference RF signal.

### (3) Noise squelch

The audio output is squelched to eliminate noise which may be heard when there is such excessive interference RF signal that the tone squelch does not work.

## Resetting the Accumulated Time Indication

The time indication accumulates time in hours and minutes when the WRR-861A/861B is on.

Reset the indication to "00:00" whenever you replace the batteries so that it can display the running time of the batteries.

**1** Press the MODE button until the accumulated time appears.

**2** Press the SET button.

Accumulated operating  
time

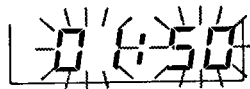

**3** Press the - button.

The time indication resets to "00:00."

While you see "00:00" is flashing, you can go back to previous value by pressing the + button.

**4** Press the SET button.

## Selecting the Backlight Mode

You can select the backlight mode of the display.

- 1 Press the MODE button until the backlight mode appears.
- 2 Press the SET button.  
The backlight indication starts flashing.

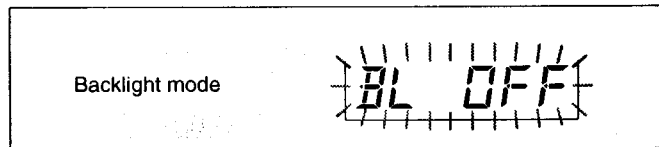

- 3 Press the + or - button to select the desired mode.  
BL OFF : Lights off all the time  
BL ON : Lights on all the time  
BL AT : Lights on when you begin to operate the tuner. Turns off automatically 15 seconds after you finish operation.
- 4 When the desired mode appears, press the SET button.  
The display stops flashing and the selected mode is now stored in memory.

## Attaching to a Camcorder

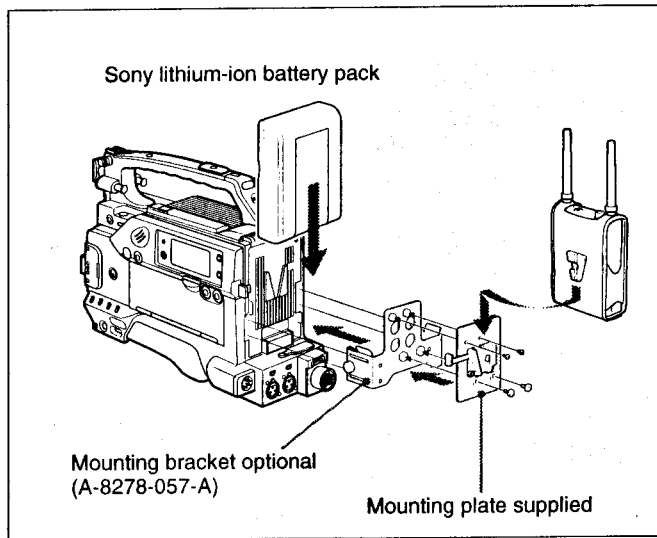

When the Sony lithium-ion battery pack is attached on the camcorder, both the mounting bracket optional (A-8278-057-A) and the mounting plate supplied are required. When attaching the Sony nickel-cadmium battery, use only the supplied mounting plate.

To release the tuner from the mounting plate, push in the lever on the plate.

# Error Messages

When a problem occurs, one of the following error message may appear on the display.

<b>Messages</b>	<b>Contents</b>	<b>Measures</b>
ERROR 03	The battery voltage exceeds the allowable value.	Use the specified batteries.
ERROR 11	An error occurred in backup memory data.	Contact your Sony dealer.
ERROR 21	The PLL synthesized circuit is in trouble.	
ERROR 51	Defect of the A/D converter.	

# Troubleshooting

If you have any problem using the tuner, use the following checklist. Should any problem persist, consult your Sony dealer.

Symptom	Meaning/Remedy
The tuner does not turn on.	<ul style="list-style-type: none"><li>• The + and – polarities of the batteries do not match those of the battery compartment. → Install the batteries with the polarities correctly matched.</li><li>• The batteries are exhausted. → Replace the batteries with new ones.</li><li>• The battery terminals in the tuner are dirty. → Clean the + and – terminals with a cotton swab.</li></ul>
The batteries run down quickly.	<ul style="list-style-type: none"><li>• The batteries are exhausted. → Replace the batteries with new ones.</li><li>• A manganese batteries are being used. → Use the alkaline batteries. The battery life of a manganese battery is less than half that of an alkaline battery.</li><li>• The tuner is being used under cold conditions. → The batteries run down quickly under cold conditions.</li></ul>
The channel cannot be changed.	The SET button is not pressed. → Press the SET button to flash the GP/CH indication on the display section, then change the channel with the + and – buttons. After setting the channel, press the SET button again to turn on the GP/CH indication.
There is no sound.	<ul style="list-style-type: none"><li>• The channel setting on the tuner is different from that on the microphone. → Use the same channel setting for both the tuner and microphone.</li><li>• The RF indications do not turn on. → Confirm that the microphone is turned on.</li></ul>
The sound is weak.	<ul style="list-style-type: none"><li>• The attenuation level of the microphone is too high. → The output level of the microphone is too low. Decrease the attenuation level of the microphone.</li><li>• The volume on the amplifier or mixer is low. → Adjust the volume.</li></ul>

# Troubleshooting

Symptom	Meaning/Remedy
<p><b>There is distortion in the sound.</b></p>	<ul style="list-style-type: none"> <li>• The attenuation level of the microphone is too low, or the audio is not attenuated at all. ♦ The level of the audio input to the microphone is extremely high. Increase the attenuation level of the microphone.</li> <li>• The channel setting on the tuner is different from that on the microphone. ♦ Use the same channel setting for both the tuner and microphone.</li> </ul>
<p><b>There is sound interruption or noise.</b></p>	<ul style="list-style-type: none"> <li>• The RF indicator on the tuner lights even when the microphone is off. ♦ Jammed transmissions are being received. Determine which channels are usable (i.e., channels for which the RF indication on the tuner does not light) and set the microphone to the same usable channel. When two or more microphones are used, select other channel group where no jammed transmissions are being received.</li> <li>• The channel setting on the tuner is different from that on the microphone. ♦ Use the same channel setting for both the tuner and microphone.</li> <li>• Two or more wireless microphones are set to the same channel. ♦ Make sure no two microphones are set to the same channel. Set each microphone to a different channel.</li> <li>• The microphones use channels from different groups. ♦ The channel groups are specified so that no mutual interference occurs when 2 or more microphones use the channels within the same group. Specify channels within the same group for all the microphones being used.</li> <li>• The SQUELCH switch is set to OFF. ♦ When receiving condition is poor, noise may be produced due to the jammed transmissions. Improve the receiving condition and turn on the SQUELCH switch.</li> <li>• The SQUELCH switch is set to ON. ♦ When receiving condition is poor and RF input level drops below the specified RF squelch level, audio output from the tuner is cut and audio drop-out occurs. If this happens, improve the receiving condition. Turning off the SQUELCH switch avoids audio drop-out, but noise may be produced.</li> </ul>

# Specifications

## Tuner section

Type of reception	Space diversity
Circuit system	Dual conversion superheterodyne
Receiving frequencies	Model available in the U.S.A. : one frequency within 758 to 782 MHz (6264 model) one frequency within 782 to 806 MHz (6668 model) Model available in Australia: one frequency within 792 to 806 MHz

Local oscillators	1st: Crystal controlled PLL synthesizer 2nd: Crystal oscillator
-------------------	--

Antenna connectors	BNC-R (2)
RF input impedance	50 $\Omega$
RF squelch level	5 dB $\mu$ / 10 dB $\mu$ / 15 dB $\mu$ or OFF selectable

Frequency response	40 Hz to 18 kHz
De-emphasis	50 $\mu$ s
Selectivity	60 dB or more (at $\pm$ 250 kHz detuned)

Spurious rejection ratio	70 dB or more
--------------------------	---------------

Image rejection ratio	60 dB or more
Signal-to-noise ratio	30 dB or more at 10 dB $\mu$ RF input 60 dB or more at 60 dB $\mu$ RF input ( $\pm$ 5 kHz deviation at 1 kHz modulation, A-weighted)

Distortion	1% or less ( $\pm$ 40 kHz deviation at 1 kHz modulation)
------------	---

Tone squelch frequency	32.768 kHz
Output connectors	SMC9-4S (1)
Output level	-58 dBm ( $\pm$ 5 kHz deviation at 1 kHz modulation)

Output impedance	150 $\Omega$ , balanced
Monitor connector	3.5 mm ( $5/32$ inch) dia. stereo mini jack

## General

Power requirements	Batteries: 6 V DC , four alkaline batteries LR6 (size AA) External: 12V DC
--------------------	---

Current consumption	Batteries: Approx. 140 mA at 6V DC External: Approx. 85 mA at 12 V DC
---------------------	--

---

0 dB $\mu$  = 1  $\mu$ V<sub>RMS</sub>

0 dBm = 0.775 Vrms (600  $\Omega$  loaded)

# Specifications

Battery life	8 hours or more of continuous use with four Sony LR6 alkaline batteries at 25°C
Operating temperature	0 °C to +50 °C (32 °F to 122 °F)
Storage temperature	- 20 °C to +60 °C (- 4 °F to +140 °F)
Dimensions	89 × 120 × 29.5 mm (w/h/d) (3 <sup>5</sup> / <sub>8</sub> × 4 <sup>3</sup> / <sub>4</sub> × 1 <sup>3</sup> / <sub>16</sub> inches)
Mass	400 g (14 oz) including batteries

## Supplied accessories

- Antennas (2)
- Output cable (1)
- DC power cable (1)
- Mounting plate (1)
- Attachment case (1)
- Operating instructions (1)
- Wireless Microphone System Frequency List (1)

## Optional accessory

- Mounting bracket (A-8278-057-A)  
(For details, contact your Sony dealer.)

Design and specifications are subject to change without notice.